

MICROWAVE 320

DATA SHEET
Position & Level
Control



Approved with MT 851/MR 851 Sensors

FUNCTION

Single Point Switch for on-off control of bulk solids and liquids. ON-OFF Switch presence/absence, indication of objects.

TYPICAL USES

High Level Alarm or Control

Plugged Chute Detection

Truck and RR Car Position

Flow/NoFlow Sensing of Bulk Materials in Chutes, on Conveyors

PRIMARY AREAS OF APPLICATION

Severe Environments

Where the environment is too hostile to permit reliable operation of photo-electric controls. Microwave 320 is unaffected by dust, smoke, fog or vibration.

High Temperature Environments

Model MT 861 and MR 861 transmitters and receivers are designed for high temperature service. Please note: These sensors are water cooled to maintain an operating temperature of +140°F (+60°C) or less at the pre-amplifier.

Abrasive Materials

Eg: Crushed coal, sand, ore. Rugged construction. No moving parts. Sensors do not protrude into flow stream.

Corrosive - Liquid Products

Eg: Water, acids, diluted acids (within the limits of transmitter and receiver housing and insulation materials), water with impurities.

Liquids - Interface

Eg: Petroleum products and water.

Liquids - With Solids

Eg: Municipal waste (sewage).



■ FEATURES

Approved

All Microwave Type 1 Controls comply with FCC rules Part 15 and are approved by the FCC as being suitable for industrial applications. These controls have an average power density of 0.1 mw/cm² at the antenna, well below OSHA guidelines. No licenses or approvals required to use the controls.

Non-Contact

Sensor does not contact subject when used as a position indicator control.

No Vessel Openings

Sensors can see through most non-metallic vessels.

Non-Intrusive

When the Microwave 320 is used for level control, transmitter or receiver sensors do not protrude into vessel so bridging cannot occur.

Independent Time Delays

Standard, for smooth, chatter-free performance. Field adjustable.

Corrosion Resistant, Watertight

Remote Enclosure

Glass-reinforced polyester enclosure features captive hardware and stainless steel trim to endure the most corrosive environments.

Versatile Power Supply

The standard unit accepts 120 Volts AC, 240 Volts AC or low voltage 24 DC input.

Long Cables

Pre-amplifiers are located at transmitter and receiver permit use of long cable lengths up to 1,000 feet (340.8m).

Fail-Safe

A simple field selectable slide switch determines the high or low fail-safe mode.

■ PRINCIPLE OF OPERATION

These controls are non-contact sensing microwave based controls. The transmitter (source) consists basically of a power supply, pulse modulator, Gunn oscillator, and directional antenna. The receiver consists of a directional antenna, a microwave mixer cavity with a Schottky barrier diode detector, a high gain, low noise amplifier, a pulse coding network, a voltage comparator circuit and a relay driver circuit.

In the transmitter, power is converted to a well regulated and filtered 12 Volts DC supply. It is then pulsed at about 1 kHz by the pulse modulator circuit. This circuit is included to permit pulse discrimination circuitry to be used. In addition, pulsing at a 10% duty cycle safely permits peak transmitted power levels 10 times greater than permitted under continuous wave operation. The pulsed DC is fed to a Gunn oscillator in the antenna assembly, where the 12 Volts DC 1 kHz square wave is converted to a pulsed X band (10.525 GHz) microwave signal. The signal is radiated by the directional antenna, which is typically a 10dB gain horn with a beam spread of approximately 40°.

In the receiver, the signal is received by a directional antenna and coupled to a mixer cavity containing a Schottky detector diode. This diode converts the low level microwave signal to a low level pulsed DC, which is then amplified by an adjustable gain — low noise IC amplifier to a 0-10 Volts DC control signal. This system is interconnected and uses pulse discrimination coding. In these systems the receiver is on only when the transmitter is on, thus the system is virtually immune to false triggering from stray microwave interference. The level of the amplified received signal (0-10 Volts DC) is compared with a preset value in a voltage comparator circuit. When the signal received exceeds the comparator set-point, an output signal is initiated which is processed through time delay circuits to drive the output relay.

A microwave system has been described in the above, based on a fixed power transmitter and a receiver/detector with adjustable gain to discriminate between various signal power levels received at its antenna. Materials in the industrial environment have various effects of microwave signals. For example, low level microwaves cannot penetrate metals, but are reflected by them. They are absorbed almost entirely by water, and to varying degrees by water based solutions or products that have a significant moisture content such as grain, wood products, etc.

Transmission losses increase with increasing dielectric constants and increase with increasing conductivity. For example, air (dielectric constant of 1 and conductivity of zero) transmits microwave with no loss while sea water (dielectric constant of 55 at X-band and conductivity of 4 mhos/meter) provides extreme attenuation of the microwave energy. It is the material's dielectric constant and conductivity that determine whether or not the material is a good candidate for microwave control.

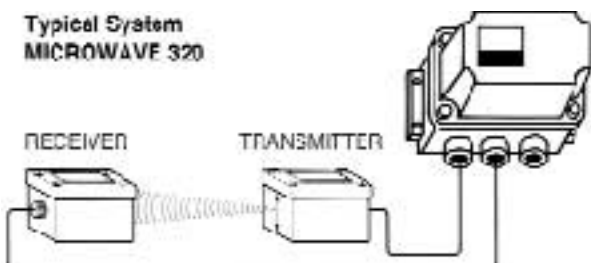

■ TYPICAL APPLICATIONS

Level Control

Level control of liquids or solids in tanks, bins, hoppers or chutes are some typical applications. Non-conductive-fiberglass tanks represent minimal losses to X-based microwaves. Sensors are mounted on the outside, opposite one another on the tank. Losses through the tank walls and air or vapors above the product are low. When the product level reaches the control position, the signal is attenuated significantly, causing the output relay to change state. Metal tanks or hoppers must have a "window" transparent to micro-wave signals. Sightglasses (3"-4" dia.) can be used on liquid storage tanks, compatible with the pressures, temperatures and chemical properties of the materials stored in the tank. For metal vessels storing solid materials, "windows" can be constructed of materials such as high density polyethylene or other similar substances compatible with the produce contained therein. A partial list of materials low in loss are below. These are potential candidates for windows.

■ TYPICAL WINDOW MATERIALS

- Fiberglass
- Glass (no lead)
- Lexan®
- Lucite®
- Magnesium Firebrick
- Mica
- Nylon
- Paraffin
- Plexiglass
- Polyethylene
- Polystyrene
- PVC
- Quartz
- Styrofoam
- Teflon

■ SPECIFICATIONS

Input Voltage	NOMINAL 115 Volts AC 230 Volts AC 24 Volts DC	ABSOLUTE LIMITS 95-135 Volts AC 190-270 Volts AC ±4 Volts
Power	5 volt-amperes	
Frequency	50-60 Hz	
Time Delay	Independent with auto reset on make, or break	
Delay Time Range	50 minimum - 10 second nominal 30 second maximum	
Fail-Safe Switch Selectable	High Level or Low Level — High Level Fail-Safe Position: Relay is de-energized when material is present Low Level Fail-safe Position: Relay is de-energized when no material is present	
Indicators	Two, light emitting diodes (LED) RED - illuminated when material is not present at sensor—path is complete YELLOW - illuminated when relay is energized	
Operating Temperature (Amplifier)	-40°F to +160°F (-40°C to +71°C)	
Output	Relay, DPDT Form C	
Ratings	5 amp @ 120 Volts AC resistive 3 amp @ 240 Volts AC resistive 3 amp @ 24 Volts DC resistive	
Operating Temperature (Transmitter/Receivers)	See Page 26 for details.	

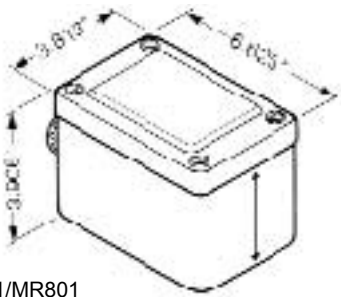
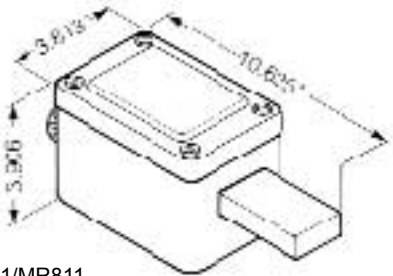
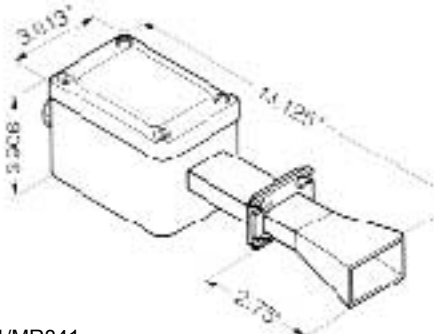
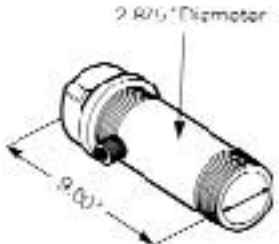
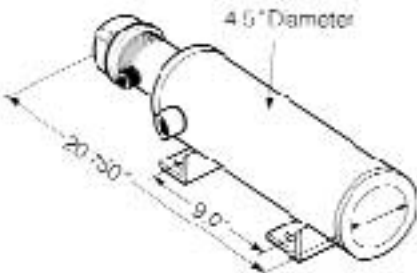

SENSORS (Transmitters & Receivers)

Sensor & Model No.	Description	T	ypical Applications
 <p>MT801/MR801</p>	<p>Long range transmitting/receiving sensors with 10db gain home antennas Maximum range 100' in air. NEMA 4x enclosures, MT801/MR801 temperature range: -20°F to +140°F (-30°C to +60°C).</p>		<p>Standard Service Vehicle detection, railroad car detection & positioning. Liquid level control, bin level control (sand, rock, asphalt, coal, cement, fly ash, etc.) Use with Part #41121 window.</p>
 <p>MT811/MR811</p>	<p>Short range accurate high/low level detection. Range up to 10' in air. Used primarily for accurate position and level sensing of bottles, small boxes, etc. NEMA 12 enclosures. Temperatures range: -20°F to +140°F (-30°C to +60°C).</p>		<p>High/low level detection, empty bottle detection, battery filling level control, empty box detection counting, short range plugged chute.</p>
 <p>MT841/MR841</p>	<p>Similar to MT811/MR811 except 10 db gain horn antennas are used. Designed to be used in Part No. 41105-X, waveguide extension kit. Maximum range 100' in air, Enclosures is NEMA 12. When used with 41105-X, maximum temperature at antenna is 600°F (313°C). Amplifier maximum temperature is 140°F (60°C)</p>		<p>Waveguide with 10 db gain horn antenna. Level control when vessel or environment is extremely hot. Furnaces, kilns, cupolas, fly ash, furnace fluidized beds, etc. Use with Part #41121, #41213 and with castable refractory materials.</p>
 <p>MT851/MR851</p>	<p>Identical to MT801/MR801 except sensors are constructed in 2 1/2" steel pipe. Designed to be screwed directly into steel vessels using 2 1/2" weldment (P/N41249-order separately). Window material is FDA approved UHMW polyethylene 1" thick. Contact factory for other available material. Temperature range: -20°F to +140°F (-30°C to +60°C).</p>		<p>Severe service. Bin level control of sand, rock, asphalt, coal, etc. In areas where physical abuse of sensor is possible. Rugged.</p>
 <p>MT861/MR861</p>	<p>Similar to MT851 and MR851 except waveguide 10db horn and electronics is located inside water cooled jacket.</p>		<p>Hot product, water cooled Level control of limestone, ores and other products contained in firebrick enclosures.</p>



ACCESSORIES
(Mounting)

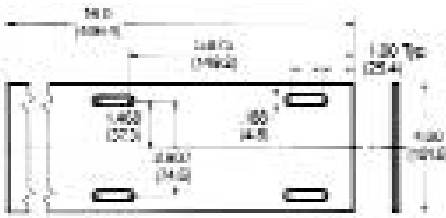

Part No. 41347
Mounting Support Plate for MT/MR801,
MT/MR811, MT/MR841 systems.

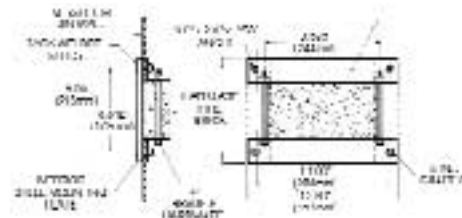

Part No. 43681
Microwave Firebric Window Assembly

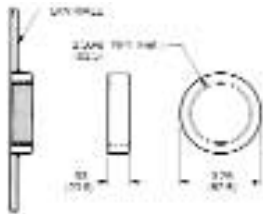

Part No. 41249-2
Weldment for MT/MR851.

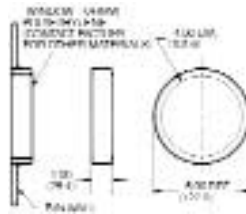

Part No. 41121
Microwave UHMW Polyethylene,
Lexan® or Teflon® Window use
with MT/MR801, MT/MR811,
and MT/MR841 systems.



Part No. 41213
High Temperature Glass Window for use and
Weldment with MT/MR841 and MT/MR811.
Maximum Ratings: 860°F; 500°F (260°C) @ 0
PSI; 70°F (21°C) @ 450 PSI.

ACCESSORY ITEMS

In certain cases it may be necessary to “pipe” waveguide around existing obstructions, extensions and elbows are available.



Part No. 41105-X
Waveguide Extension Kit
(includes mounting hardware)

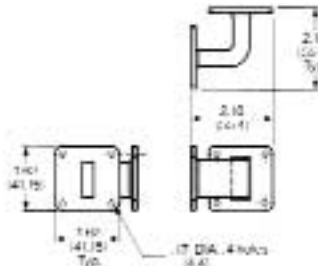

Part No. 41361 90°
Right Angle Waveguide “E BEND”
(includes mounting hardware)

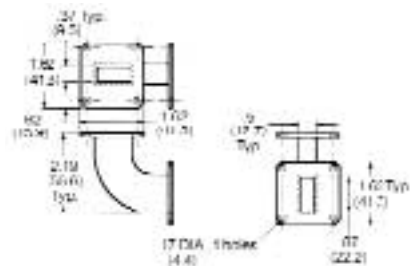

Part No. 41524 90°
Right Angle Waveguide “H BEND”
(includes mounting hardware)

CABLE ASSEMBLIES

Part No.	Type	Description
17102	General Purpose	50 ft. (16 meters). 2 Conductor Shielded PVC Jacketed Cable Temp Range -40°F to +160°F (-40°C to +70°C)
42564	General Purpose	100 ft. (33 meters). 2 Conductor Shielded PVC Jacketed Cable Temp Range -40°F to +160°F (-40°C to +70°C)
17198	High Temperature	2 Conductor Shielded Teflon® Jacketed Cable Temp Range -40°F to +400°F (-40°C to +204°C)



TIME DELAY SETTINGS

Bin Level Control

Normally requires both time delays to insure that a turbulence upper level will not cause a false trip. Clockwise rotation of Beam Make and Beam Break increases time delay.

Plugged Chute Control

Applications will normally have delay on Beam Break so that falling material will not trip the control relay prematurely.

Starvation Control

Applications require delay on Beam Make so that when product ceases to flow (starvation) the relay will not operate until some reasonable time period has elapsed. This prevents false signals due to temporary reduction in flow.

Object Detection Control

Such as vehicle washing equipment require about 1/2 second delay on Beam Make and Beam Break to prevent false signals.

General Comments

Always use as much time delay as the application will permit. These time delay adjustments permit custom application of the Microwave 320 System to your specific process needs.



CSA APPROVED WITH
MT/MR 851 SENSORS FOR
Class II, Division 1 —
Groups E, F & G hazardous locations.



FM APPROVED WITH
MT/MR 851 SENSORS AS
DUST IGNITION PROOF FOR
Class II, Division 1 —
Groups E, F & G hazardous locations.

ORDERING INFORMATION

MICROWAVE

320-

Interconnect Cable

- P50 = Pair of 50 ft. PVC Cables,
2 Conductor
- P100 = Pair of 100 ft. PVC Cables,
2 Conductor
- B = Bulk PVC Cable, 2 Conductor
(Lengths over 100 ft.)
- T = Bulk Teflon Cable, High Temp
(300 ft. or Less)
- 00 = None

Mounting Options (priced per pair)

- W = Standard, 2-1/2" C.S. Weldment for 851's
- U = 4" C.S. Weldment and UHMW Window
- T = 4" C.S. Weldment and Teflon Window
- F = 4" C.S. Weldment and Firebrick
(750° F max)
- G = 2" Weldment and Quartz Glass Window
(400° F max)
- H = High Temp, 4" Lagging Extension for 851's
- A = High Temp, Angled Weldment for
Fly Ash Applications
- E = High Temp, 12" Lagging Extension for
Fly Ash Bracket
- 00 = None

Sensor Type (priced per pair)

- 851 = Standard, C.S. Direct Coupled, 2-1/2" NPT
- 811 = NEMA 12, 3.9" x 3.8" x 6.6" Enclosure
with Extension
- 801 = NEMA 4X, 3.9" x 3.8" x 6.6" Enclosure
- 861 = High Temp, Water-Cooled (750°F max)
- 851S = 316 Stainless Steel, Direct Coupled, 2-1/2" NPT
- 851V = Vibration Resistant 851's
- 841 = NEMA 12, 3.9" x 3.8" x 6.6" Enclosure
with Extension and Horn

Note: 801, 811, 841, 851, 851S, 851V —
140° F max for Electronics

Enclosure Type

- S = Standard, NEMA 4X Enclosure
- C = Clear NEMA 4X Enclosure
- O = OEM, Electronic Assembly with Mounting Hardware
(No Enclosure)

Model Microwave 320 Point Level Switch

DEHAVAN Process Instrumentation
an [REDACTED] Company

Hillside, IL 60162
Ph: (708) 236-6000
Fax: (708) 236-6006
Email: sales@ljtechnologies.com

